

27249 - Supplementary Operating Manual for Type KSP 3208



This operating manual is only a supplement to the ZH operating manual 27224. Please carefully read through both manuals and observe the information contained in them.

Self-priming pump KSP. A variant of the ZH-3208 pump.

ZH 3208 is a normal multi-stage centrifugal pump with several impellers that can achieve high pressures. Several impellers, so-called stages, are built in a row on a shaft. However as a centrifugal pump, the ZH is not self-priming and also does not have dry run protection.

By integrating a suction stage in our ZH pump, additional properties such as self-priming and dry run protection are achieved. The new KSP pump can then prime liquids from a tank that is positioned lower and is not damaged by a brief dry run.

Function: The pump consists of two pump types that are mounted on a drive shaft.

A multi-stage centrifugal pump can then only operate when the inside of the pump is always filled with liquid. This works very well when the pump has an inflow or the suction line is always completely filled. For example, this is possible by using a foot valve. If the pump has a suction lift instead of an inflow and no foot valve can be used, the pump will quickly run dry and can then no longer convey any liquid or build up pressure. Here it must first be ensured that the liquid completely fills the pump and the complete suction line again.

An integrated suction stage is used here. This is positioned on the same shaft after the centrifugal pump stages. When priming, the medium from the suction tank is transported through the suction line in the pump, through all pump stages of the centrifugal pump and finally through the suction stage. This arrangement of the stages ensures that the stages of the centrifugal pump are slowly filled until the pump is fully filled with liquid.

27249 - Supplementary Operating Manual for Type KSP 3208

Start-up

- Before initial start-up, the pump must be filled with liquid one time so that the suction stage can create a vacuum. During subsequent shutdown, enough residual liquid always remains in the pump so that a restart can take place without refilling.

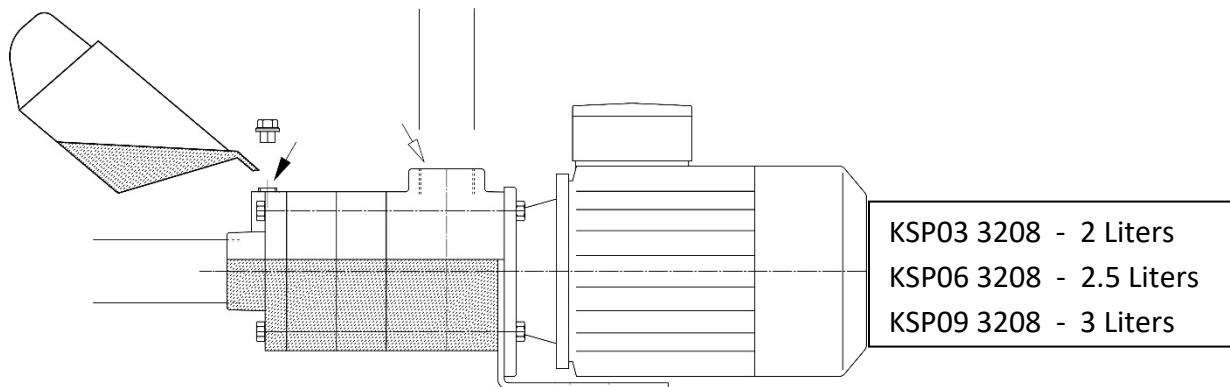

- The centrifugal pump is sealed with a mechanical seal on the shaft. This dynamic seal may not run dry and must always be lubricated with liquid. This seal was placed after the centrifugal pump stages and after the suction stage. For this arrangement, the seal is always protected against a dry run even during priming when there is very little liquid in the pump.
- The suction line (max. 3m) should be as short as possible and guided vertically (always rising!) out of the suction tank. This is decisive for a good suction function of the pump. Suction lifts up to max. 2m are possible.
- When priming, air is first drawn into the inside of the pump. A ventilation option must be provided. The pressure line must be open (without non-return valve) or a small ventilation line should be installed.

27249 - Supplementary Operating Manual for Type KSP 3208

Troubleshooting

See also BA 27224

Error	Cause of the malfunction	To eliminate the malfunction
Pump does not suck	Pump empty, no liquid in the pump.	Fill pump with liquid before start-up
	Suction lift or suction losses too high	Shorten suction line, always install rising! Maximum suction lift of 2m possible.
	Suction line leaky	Check suction line
	Pressure line is closed, ventilation option missing	Open pressure line (without non-return valve) or install ventilation bypass
	Wrong direction of rotation	Check direction of rotation, observe arrow; for incorrect direction of rotation, swap the two phases in the terminal box
	Parts of the suction stage worn	Replace entire suction stage with a new one

27249 - Supplementary Operating Manual for Type KSP 3208

Disassembly

- Removal of the pump, draining and preparation for disassembly are described in in BA 27224.
- Start at the suction side when dismantling the pump. The suction cover (162) and the normal stages (147) with impellers (233) are removed as described in BA 27224.
- Disassembly of the suction stage; suction stage Pos.111 is an assembly that can only be completely replaced if required. Please observe the spare parts drawing.
- After removing the suction stage (Pos.111), proceed further as described in BA 27224.

Reassembly

- Assembly is essentially disassembly in the reverse order.
- Check all parts for wear. Damaged parts must always be replaced by new ones. Mechanical seals and all other seals are not wear-free and should be checked for damage.



Use only original spare parts for repairs! During reassembly all seals must be replaced.

Observing these instructions is a precondition for problem-free operation of the pump and for honouring any warranty claims that may be submitted.

27249 - Supplementary Operating Manual for Type KSP 3208

Spare parts drawing

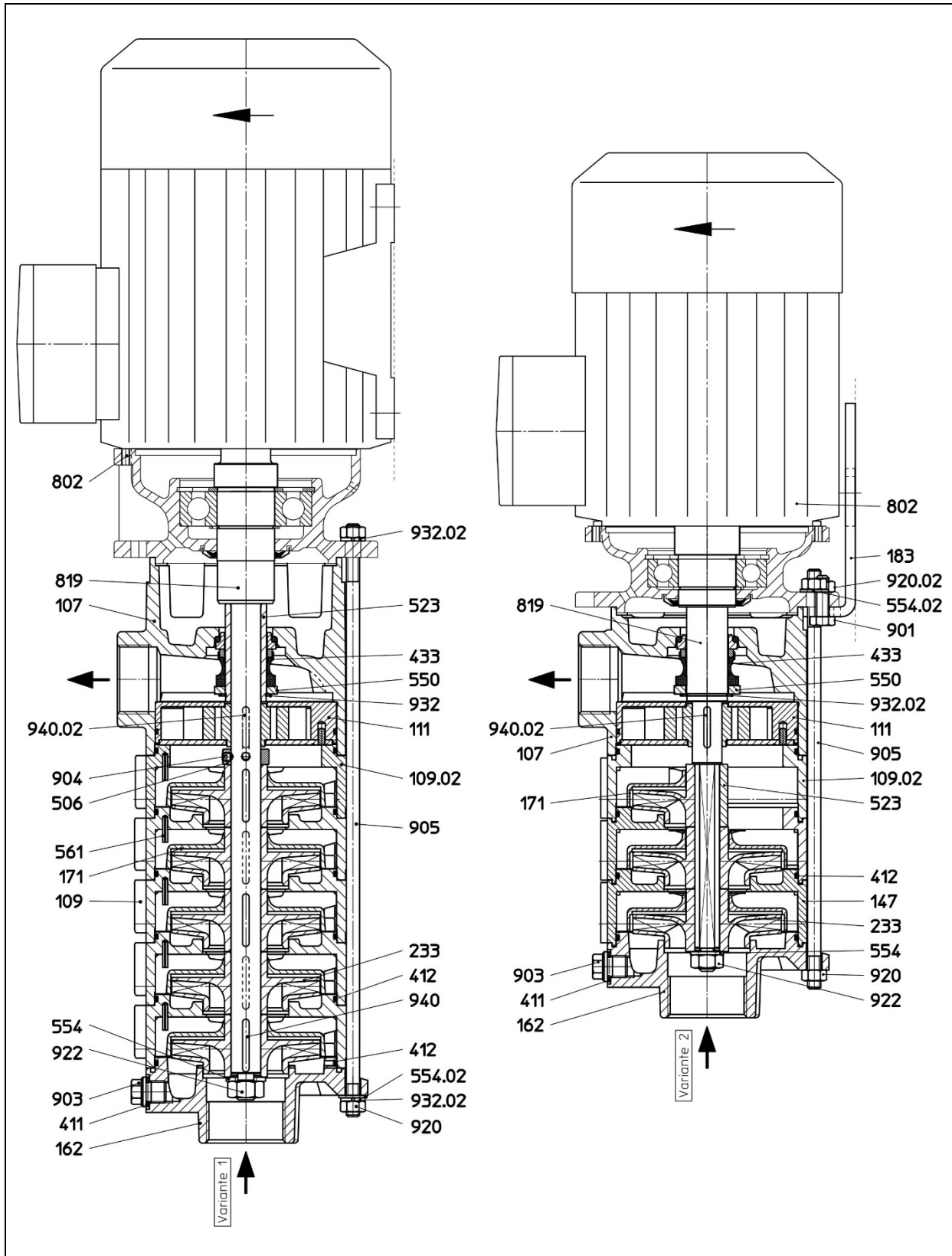

27249 - Supplementary Operating Manual for Type KSP 3208

Spare parts list

Item	Name	
107	Pressure housing	
109	Stage casing	
109.02	Stage casing (idle stage)	
111	Priming stage, complete	
147	Stage casing complete with distributor	(plastic)
162	Suction cover	
171	Distributor to 109	
233	Impeller	
411	CU-ring to 903	
412	O-ring to 109+147+162	
433	Mechanical seal complete	
506	Set collar	
523	Shaft sleeve	
550	Distance washer to 433	
554	Distance washer to 922	
554.02	Distance washer to 905	
802	Block motor	
819	Motor shaft	
903	Plug screw	
904	Threaded pin to 506	
905	Connecting screw	
920	Hexagonal nut to 905	
922	Impeller cap nut	
932.02	Retaining ring to 433	
940	Key to 109+147	
940.02	Key to 111	

Not all parts are installed in every pump.



Suction stage Pos.111 is an assembly that can only be completely replaced if required.

**UK
CA**

Importer:

IPP - Industrial Process Pumps Ltd.
22-30 Dunton Close
West Meadows Industrial Estate
Derby DE21 6XB
United Kingdom
www.ipp-group.com

Manufacturer:

© 2022 Schmalenberger GmbH + Co. KG
Strömungstechnologie
Im Schelmen 9 – 11
D-72072 Tübingen / Germany

Phone: +49 (0)7071 70 08 - 0
Fax: +49 (0)7071 70 08 - 14
Internet: www.schmalenberger.de
E-mail: info@schmalenberger.de

All rights reserved. Manual is subject to changes.